



More Precision

optoNCDT ILR // Laser distance sensors





- Measuring ranges up to 250m with reflector
- Short response time
- Excellent price-performance ratio
- Fast sensor set configuration via touch keys

Distance sensors of the series optoNCDT 1021/1101/1151 are designed for non-contact measurements against objects up to 250m. These distance sensors need a special reflector on the measurement object with the sensor being matched to its reflective properties. The use of this reflector facilitates measurement distances of up to 250m with excellent accuracy.

Precise sensor alignment

The aiming laser can be turned on for accurate alignment of the sensor with the measurement object. With large measurement distances this laser is adjusted using the optical alignment aid available as an accessory. For mounting the sensor a mounting bracket and a fine adjuster are available as accessories, which simplify the precise alignment of the sensor to the measurement object

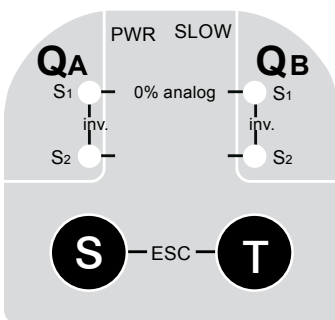
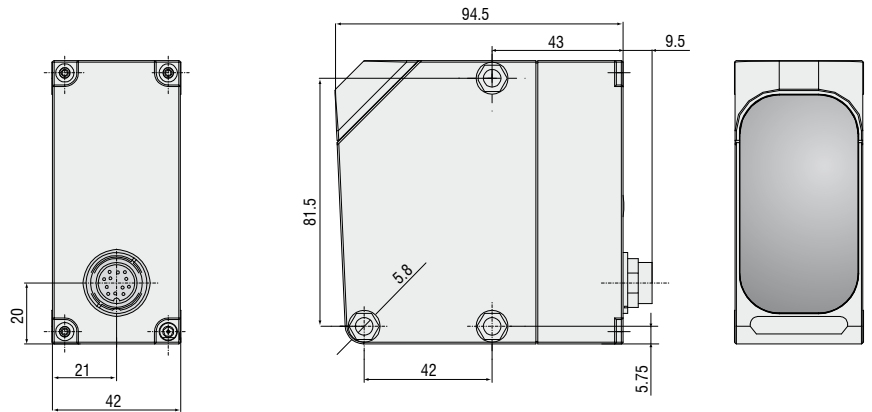

ILR1021: Limit switch programming via touch keys



ILR1101/ILR1151: Limit switch programming via software

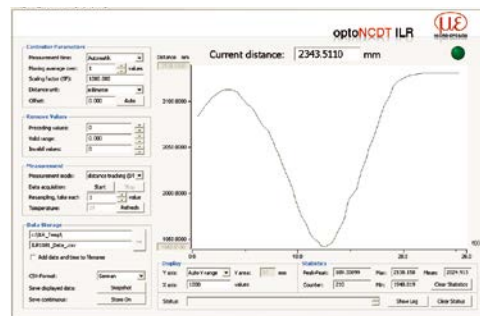

Model	ILR1021-30	ILR1101-50	ILR1151-250
Measuring range	0.2 ... 30m	0.5 ... 50m	0.5 ... 250m
	reflector required for operation		
Linearity	±60mm	±5mm ¹⁾	±3mm ¹⁾
Resolution	1 ... 5mm	0.1 or 0.125mm	
Repeatability	±5/10mm ²⁾	±4mm	±2mm
Response time	65/30ms ²⁾	12ms	
Laser class	measuring laser	IR 905nm, laser class 1	IR 900nm, laser class 1
	sighting laser	red 650nm, laser class 2	
Operation temperature ³⁾	-10° ... +50° C; -20° ... +50° C in continuous operation (humidity 5 - 95%, no condensation)		
Storage temperature	-30° ... +75°C		
Limit outputs	QA/QB (max. 100mA)		
Switching points	free adjustable (teach in)	adjustable in 1-mm-steps	
Switching hysteresis	30mm	min. 20mm (adjustable)	min. 10mm (adjustable)
Plausibility output	-	QP (max. 50mA)	
Service output	-	QS (max. 50mA)	
Serial interface	-	RS422 (2.9ms at 57.6kBaud) SSI - compatible (GRAY/BINÄR adjustable) (SSI Zyklus 80µs)	
Bus interface	-	Profibus or DeviceNet via respective gateway (accessory)	
Analogue output	4 ... 20mA	-	-
Temperature stability	<1.2mm/°C	<0.5mm/°C	<±5mm absolut
Supply	18 - 30 VDC		
Max. consumption	<3W at 24V		
Connection	5-pin connector M12	12-pin connector M16	
Protection class	IP 67		
Material (housing)	ABS shock resistant		
Vibration	EN 60947-5-2	10 - 55Hz, amplitude 1.5mm, period 5min. at resonant frequency or 55Hz, stress time 30min. per axis	
Shock	EN 60947-5-2	acceleration 30g, pulse duration 11ms, half sinusoid, 3 shocks/axis	
Weight	appr. 200g	appr. 230g	
Accessoires	page 14 - 15		

All data regarding accuracy and distance are based on the specified surface at constant ambient conditions and with a minimum operating time of 15 minutes.

¹⁾ min. distance 2m

²⁾ slow/fast

³⁾ when crossing 0°C an additional heating may be required

Operating Mode Laser Class 1 (Infrared)
Setup Mode Laser Class 2 (Visible - Red) Do not stare into beam λ: 650 nm t _p : 0,25 µs; T: 2,5 µs P _{max} : 3 mW
EN 60825-1. 10/2003

optoNCDT ILR 1021/1101/1151 use a semiconductor class 1 laser (operating mode) and a semiconductor class 2 laser (setup mode). With these classes no protection is needed.

Spot diameter ILR1021



Spot diameter ILR1101/1151



High performance sensors made by Micro-Epsilon



Sensors and systems for displacement and position



Sensors and measurement devices for non-contact temperature measurement



2D/3D profile sensors (laser scanner)



Optical micrometers, fibre optic sensors and fibre optics



Colour recognition sensors, LED analyzers and colour online spectrometer



Measurement and inspection systems



MICRO-EPSILON Headquarters
Koenigbacher Str. 15 · 94496 Ortenburg / Germany
Tel. +49 (0) 8542 / 168-0 · Fax +49 (0) 8542 / 168-90
info@micro-epsilon.com · www.micro-epsilon.com

MICRO-EPSILON UK Ltd.
No.1 Shorelines Building · Shore Road · Birkenhead · CH41 1AU
Phone +44 (0) 151 355 6070 · Fax +44 (0) 151 355 6075
info@micro-epsilon.co.uk · www.micro-epsilon.co.uk